

Transmission Fluid Cooler Hose/Pipe Quick-Connect Fitting Disconnection and Connection

Removal Procedure

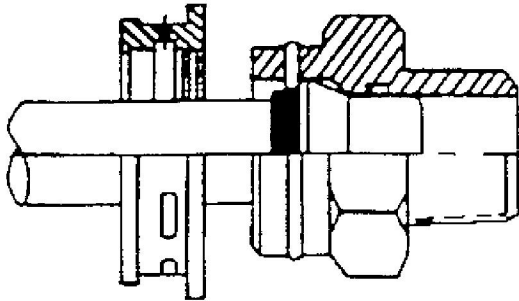

1. Remove the plastic cap from the quick connect fitting.

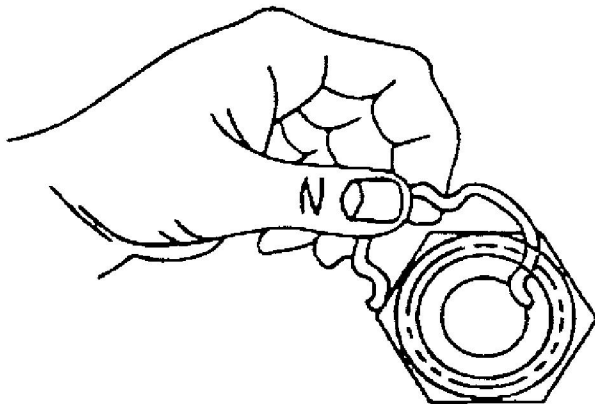

2. Remove the retaining ring from the quick connect fitting.

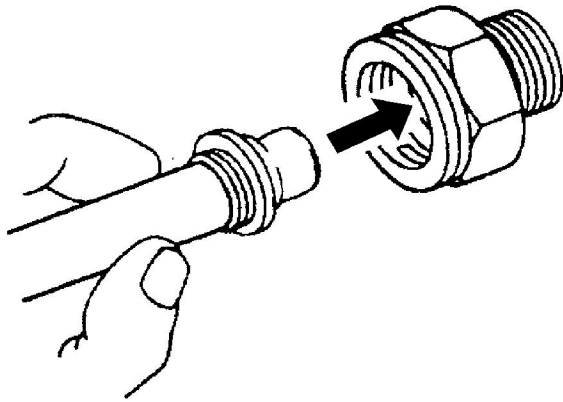

3. Remove the cooler line from the quick connect fitting.

Installation Procedure

Important:

- Do not reuse any of the existing oil lines or oil line fittings if there is excessive corrosion.
- Do not reuse any of the existing retaining rings that were removed from the existing quick connect fittings. Install new retaining rings.
- Ensure the following procedures are performed when installing the new retaining rings onto the fittings.

1. Install a new retaining ring into the quick connect fitting using the following procedure:

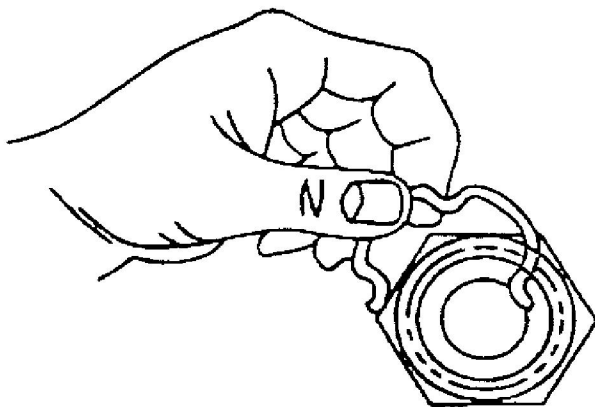



2. Hook one of the open ends of the retaining ring in one of the slots on the quick connect fitting.

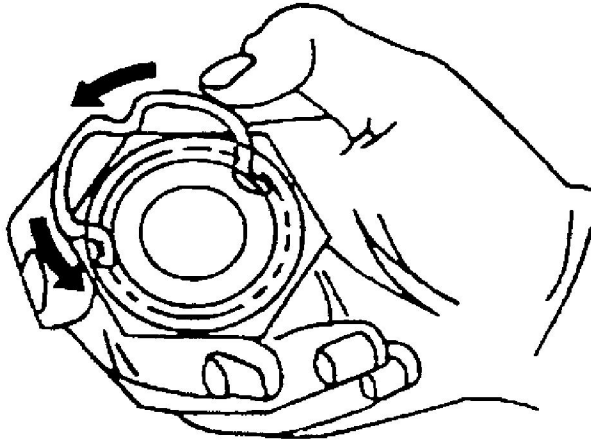

3. Rotate the retaining ring around the fitting until the retaining ring is positioned with all three ears through the three slots on the fitting.

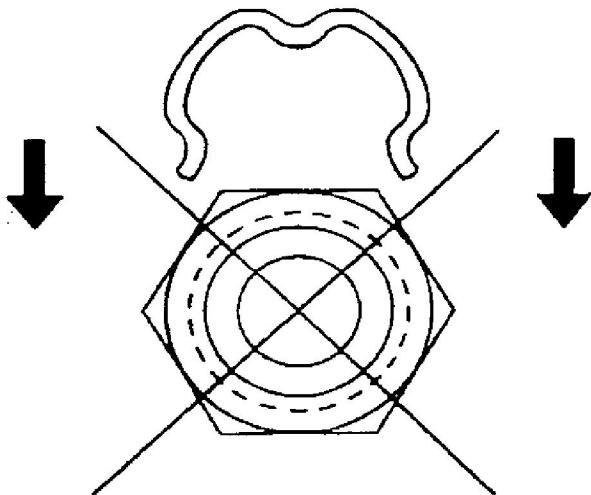

4. Do not install the new retaining ring onto the fitting by pushing the retaining ring.

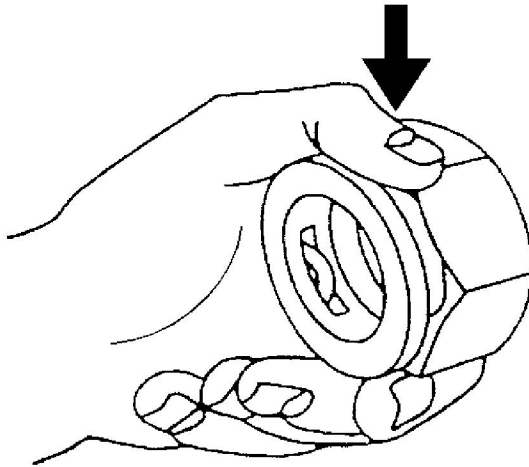

5. Ensure that the three retaining ring ears are seen from inside the fitting and that the retaining ring moves freely in the fitting slots.

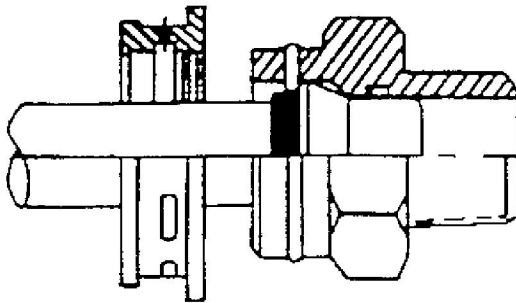

6. Install the cooler line into the quick connect fitting.
7. Insert the cooler line end into the quick connect fitting until a click is either heard or felt.

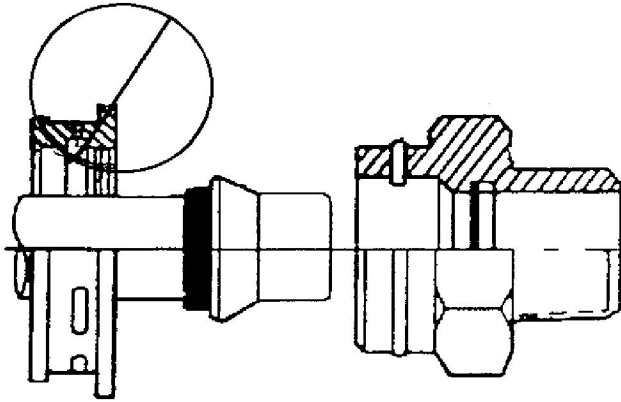

8. Do not use the plastic cap on the cooler line in order to install the cooler line into the fitting.
9. Pull back sharply on the cooler line in order to make sure that the cooler line is fastened into the quick connect fitting.

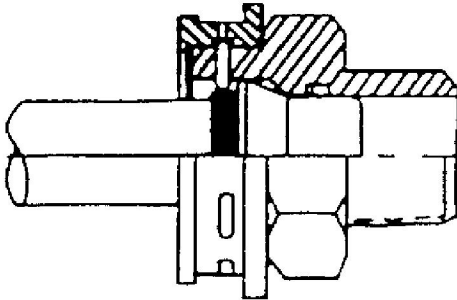

Important: Do not manually depress the retaining clip when installing the plastic cap.

10. Position (snap) the plastic cap onto the fitting. Do not manually depress the retaining ring when installing the plastic cap onto the quick connect fitting.
11. Ensure that the plastic cap is fully seated against the fitting.

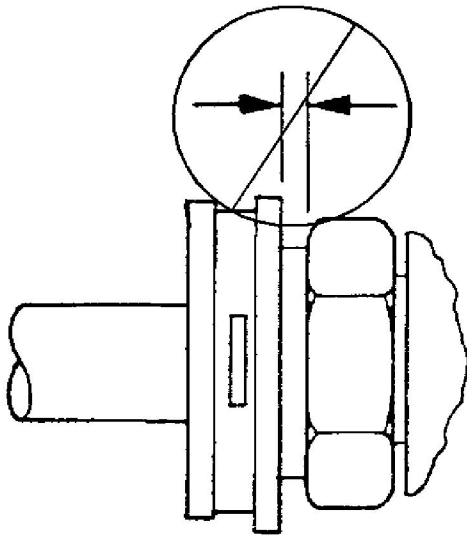

12. Ensure that no gap is present between the cap and the fitting.

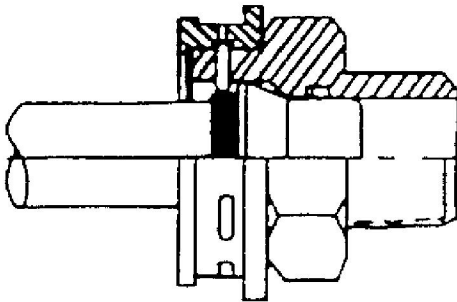

13. Ensure that the yellow identification band on the tube is hidden within the quick connect fitting.

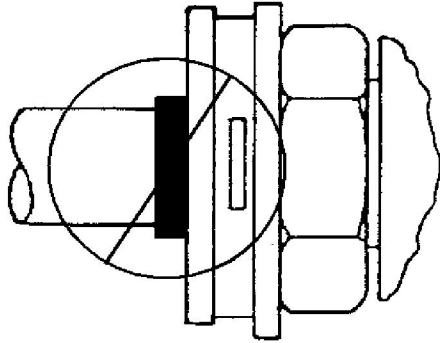

14. A hidden yellow identification band indicates proper joint seating.
15. Fill the transmission to the proper level with DEXRON® VI transmission fluid. Refer to [Transmission Fluid Check](#).