

# Manual Shift Detent Lever and Park Pawl Actuator Replacement

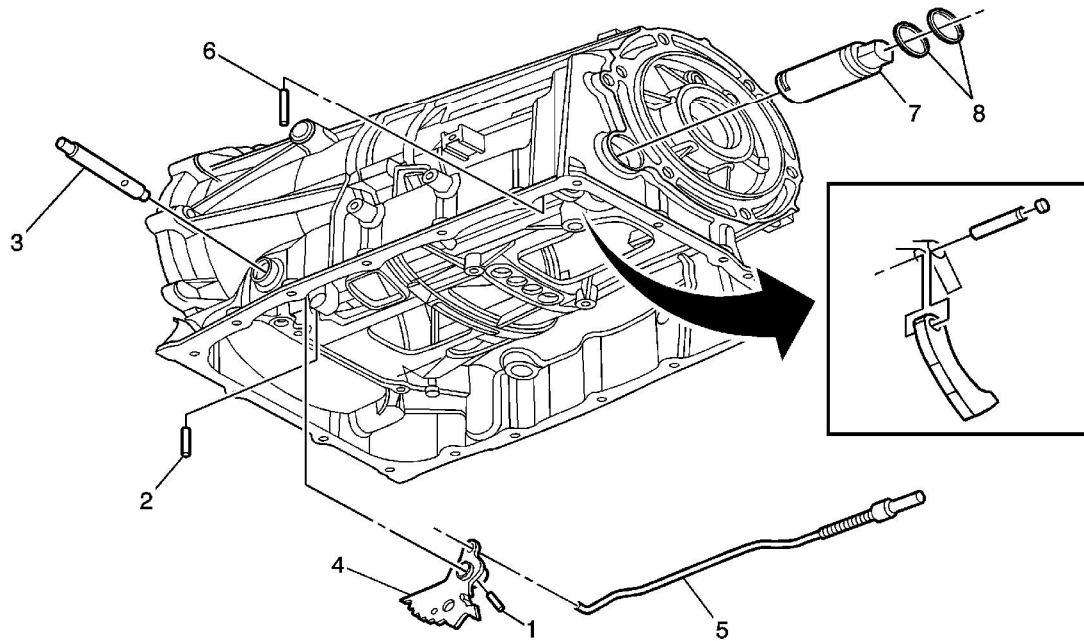

| Callout                                                                                                                                                                                                                                                                                                                                                                                                                           | Component Name                                                                                                                                                                                          |
|-----------------------------------------------------------------------------------------------------------------------------------------------------------------------------------------------------------------------------------------------------------------------------------------------------------------------------------------------------------------------------------------------------------------------------------|---------------------------------------------------------------------------------------------------------------------------------------------------------------------------------------------------------|
| <p><b>Note:</b> Do not remove the park pawl or park pawl spring. The park pawl and park pawl spring are not serviceable components.</p>                                                                                                                                                                                                                                                                                           |                                                                                                                                                                                                         |
| <p><b>Preliminary Procedures</b></p>                                                                                                                                                                                                                                                                                                                                                                                              |                                                                                                                                                                                                         |
| <ol style="list-style-type: none"> <li>1. Raise and support the vehicle. Refer to <a href="#">Lifting and Jacking the Vehicle</a>.</li> <li>2. Remove the transmission fluid pan. Refer to <a href="#">Automatic Transmission Fluid, Fluid Pan and/or Filter Replacement</a>.</li> <li>3. Remove the manual shaft detent assembly roller. Refer to <a href="#">Control Valve Lower Body and Upper Body Replacement</a></li> </ol> |                                                                                                                                                                                                         |
| <p>1</p>                                                                                                                                                                                                                                                                                                                                                                                                                          | <p>Manual Shaft Detent Lever Hub Pin</p> <p><b>Tip</b></p> <ul style="list-style-type: none"> <li>• Discard the pin. Replace with NEW pin.</li> <li>• "Walk" the pin out using side cutters.</li> </ul> |
| <p></p>                                                                                                                                                                                                                                                                                                                                                                                                                           | <p>Manual Shift Shaft Pin</p>                                                                                                                                                                           |

|   |                                                                                                                                                                                      |
|---|--------------------------------------------------------------------------------------------------------------------------------------------------------------------------------------|
| 2 | <b>Tip</b> <ul style="list-style-type: none"><li>• Discard the pin. Replace with NEW pin.</li><li>• "Walk" the pin out using side cutters.</li></ul>                                 |
| 3 | Manual Shift Shaft                                                                                                                                                                   |
| 4 | Manual Shaft Detent Lever Assembly                                                                                                                                                   |
| 5 | Park Pawl Actuator Assembly                                                                                                                                                          |
| 6 | Park Pawl Actuator Guide Pin<br><b>Tip</b> <ul style="list-style-type: none"><li>• Discard the pin. Replace with NEW pin.</li><li>• "Walk" the pin out using side cutters.</li></ul> |
| 7 | Park Pawl Actuator Guide                                                                                                                                                             |
| 8 | Park Pawl Actuator Guide (O-Ring) Seals (Qty: 2)<br><b>Tip</b><br>Discard the seals. Replace with NEW seals.                                                                         |