

# Automatic Transmission Electrical Connector Passage Sleeve Installation

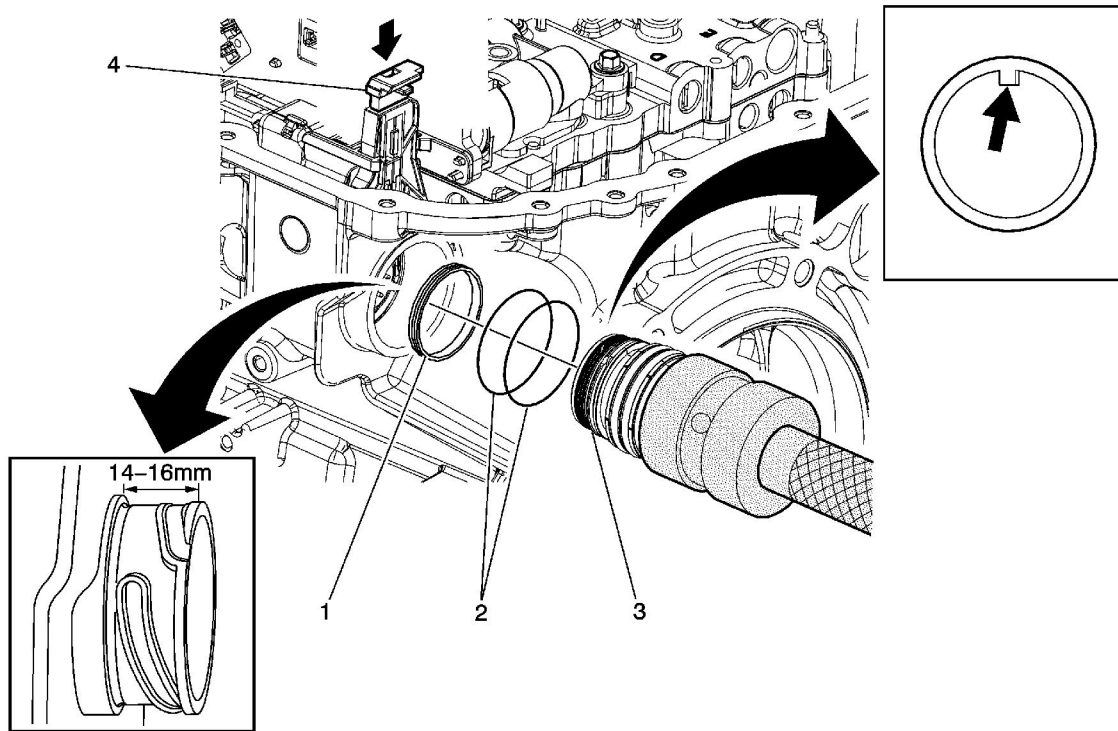

Callout	Component Name
1	NEW Lip Seal
2	NEW O-Ring Seals (Qty: 2)
3	<p>Electrical Connector Passage Sleeve</p> <p><b>Caution:</b> Orientate the alignment tab inside the passage sleeve with the slot in the electrical connector of the control solenoid valve assembly. Push the sleeve straight into the case bore and connector. Do NOT rotate the sleeve at any time. Ensure the sleeve is fully seated into the case. When the sleeve is properly installed, the distance from the case surface to the end of the sleeve should be 14-16 mm. Even though the correct electrical connections may still be maintained, failure to ensure proper installation of the sleeve may result in a fluid leak around the sleeve lip seal and into the sleeve cavity.</p> <p><b>Specification</b> 14-16 mm</p> <p><b>Special Tools</b></p>

© 2013 General Motors Corporation. All rights reserved.

	<ul style="list-style-type: none"><li>• <i>DT 47715</i> Electrical Connector Passage Sleeve Remover/Installer</li><li>• <i>J 42183</i> Driver Handle</li></ul> <p>For equivalent regional tools, refer to <a href="#">Special Tools</a>.</p>
4	<p>Electrical Connector Slide Lock</p> <p><b>Tip</b> Push down on the electrical connector slide lock to ensure proper installation.</p>